

Lecture 38

Quantum Theory of Light

The quantum theory of the world is the culmination of a series intellectual exercises. It is often termed the intellectual triumph of the twentieth century. One often says that deciphering the laws of nature is like watching two persons play a chess game with rules unbeknownst to us. By watching the moves, we finally have the revelation about the perplexing rules. But we are grateful that, aided by experimental data, these laws of nature are deciphered by our predecessors.

It is important to know that the quantum theory of light emerges alongside with this quantum theory. This new quantum theory of light is intimately related to Maxwell's equations as shall be seen. This new theory spawns the possibility for quantum technologies, one of which is quantum computing. Others are quantum communication, quantum cryptography, quantum sensing and many more.

38.1 Historical Background on Quantum Theory

That light is a wave has been demonstrated by Newton's ring phenomenon [20] in the eighteenth century (1717) (see Figure 38.1). In 1801, Thomas Young demonstrated the double slit experiment for light [270] that further confirmed its wave nature (see Figure 38.2). But by the beginning of the 20-th century, one has to accept that light is both a particle, called a photon, carrying a quantum of energy with a quantum of momentum, as well as a particle endowed with wave-like behavior. This is called wave-particle duality. We shall outline the historical reason for this development.

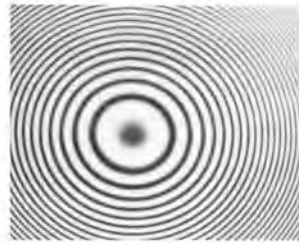
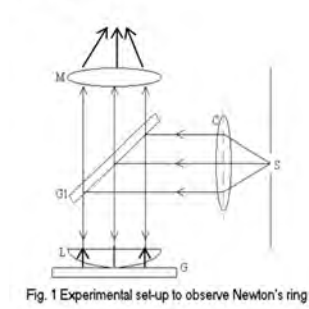
Theory

Figure 38.1: A Newton's rings experiment that indicates the wave nature of light (courtesy of [271]).

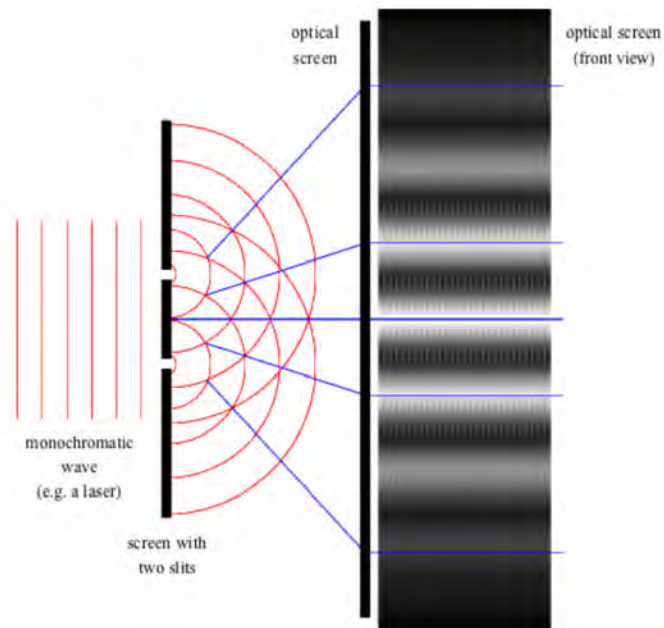


Figure 38.2: A Young's double-slit experiment. Again, the interference pattern reveals the wave nature of light (courtesy of [272]).

As mentioned above, quantum theory is a major intellectual achievement of the twentieth century, even though new knowledge is still emerging in it. Several major experimental findings led to the revelation of quantum theory of nature. In nature, we know that matter

is not infinitely divisible. This is vindicated by the atomic theory of John Dalton (1766-1844) [273]. So fluid is not infinitely divisible: as when water is divided into smaller pieces, one will eventually arrive at water molecule, H_2O , which is the fundamental building block of water.

It turns out that electromagnetic energy is not infinitely divisible either. The electromagnetic radiation out of a heated cavity would have a very different spectrum if electromagnetic energy is infinitely divisible. In order to fit experimental observation of radiation from a heated electromagnetic cavity, Max Planck (1900s) [274] proposed that electromagnetic energy comes in packets or is quantized. Each packet of energy or a quantum of energy E is associated with the frequency of electromagnetic wave, namely

$$E = \hbar\omega = \hbar 2\pi f = hf \quad (38.1.1)$$

where \hbar is now known as the Planck constant and $\hbar = h/2\pi = 6.626 \times 10^{-34}$ J·s (Joule-second). Since \hbar is very small, this packet of energy is very small unless ω is large. So it is no surprise that the quantization of electromagnetic field is first associated with light, a very high frequency electromagnetic radiation. A red-light photon at a wavelength of 700 nm corresponds to an energy of approximately $2 \text{ eV} \approx 3 \times 10^{-19} \text{ J} \approx 75 k_B T$, (where $k_B T$ denotes the thermal energy from thermal law, and k_B is Boltzmann's constant. This is about 25 meV at room temperature.¹) A microwave photon has approximately $1 \times 10^{-5} \text{ eV} \approx 10^{-2} \text{ meV}$.

The second experimental evidence that light is quantized is the photo-electric effect [275]. It was found that matter emitted electrons when light shined on it. First, the light frequency has to correspond to the “resonant” frequency of the atom. Second, the number of electrons emitted is proportional to the number of packets of energy $\hbar\omega$ that the light carries. This was a clear indication that light energy traveled in packets or quanta as posited by Einstein in 1905.

This wave-particle duality concept mentioned at the beginning of this section was not new to quantum theory as electrons were known to behave both like a particle and a wave. The particle nature of an electron was confirmed by the measurement of its charge by Millikan in 1913 in his oil-drop experiment. (The double slit experiment for electron was done in 1927 by Davison and Germer, indicating that an electron has a wave nature as well [270].) In 1924, De Broglie [276] suggested that there is a wave associated with an electron with momentum p such that

$$p = \hbar k \quad (38.1.2)$$

where $k = 2\pi/\lambda$, the wavenumber. All this knowledge gave hint to the quantum theorists of that era to come up with a new way to describe nature.

Classically, particles like an electron moves through space obeying Newton's laws of motion first established in 1687 [277]. The old way of describing particle motion is known as classical mechanics, and the new way of describing particle motion is known as quantum mechanics. Quantum mechanics is very much motivated by a branch of classical mechanics called Hamiltonian mechanics. We will first use Hamiltonian mechanics to study a simple pendulum and connect it with electromagnetic oscillations.

¹This is a number ought to be remembered by semi-conductor scientists as the size of the material bandgap with respect to this thermal energy decides if a material is a semi-conductor at room temperature.

38.2 Connecting Electromagnetic Oscillation to Simple Pendulum

The theory for quantization of electromagnetic field was started by Dirac in 1927 [3]. In the beginning, it was called quantum electrodynamics (QED) important for understanding particle physics phenomena and light-matter interactions [278]. Later on, it became important in quantum optics where quantum effects in electromagnetics technologies first emerged. Now, microwave photons are measurable and, possibly, important in quantum computers. Hence, quantum effects are important in the microwave regime as well.

Maxwell's equations originally were inspired by experimental findings of Maxwell's time, and he beautifully put them together using mathematics known during his time. But Maxwell's equations can also be "derived" using Hamiltonian mechanics and energy conservation [279]. First, electromagnetic theory can be regarded as for describing an infinite set of coupled harmonic oscillators. In one dimension, when a wave propagates on a string, or an electromagnetic wave propagates on a transmission line, they can be regarded as propagating on a set of coupled harmonic oscillators as shown in Figure 38.3. Maxwell's equations describe waves travelling in 3D space due to the coupling between an infinite set of harmonic oscillators. (In fact, methods have been developed to solve Maxwell's equations using transmission-line-matrix (TLM) method [280], or the partial element equivalent circuit (PEEC) method [195].) In materials, these harmonic oscillators are atoms or molecules, but in vacuum they can be thought of as electron-positron pairs (e-p pairs). Electrons are matters, while positrons are anti-matters. Together, in their quiescent state, they form vacuum or "nothingness". Hence, vacuum can support the propagation of electromagnetic waves through vast distances: we have received light from galaxies many light-years away.

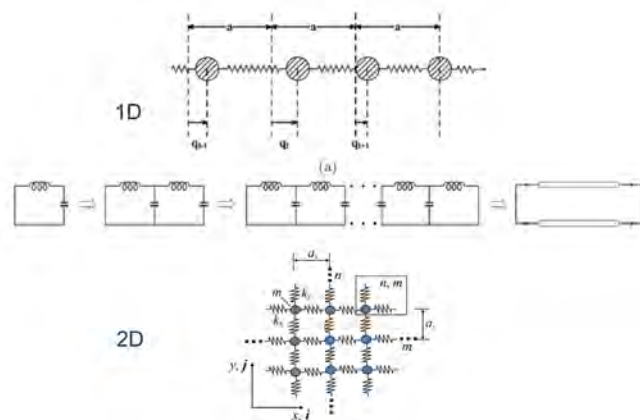


Figure 38.3: Maxwell's equations describe the coupling of harmonic oscillators in a 3D space. This is similar to waves propagating on a string or a 1D transmission line, or a 2D array of coupled oscillators. The saw-tooth symbol in the figures represents a spring.

The cavity modes in electromagnetics are similar to the oscillation of a pendulum in simple harmonic motion. To understand the quantization of electromagnetic field, we start by connecting these cavity-mode oscillations to the oscillations of a simple pendulum. It is to be noted that fundamentally, electromagnetic oscillation exists because of displacement current. Displacement current exists even in vacuum because vacuum is polarizable, namely that $\mathbf{D} = \varepsilon \mathbf{E}$ where for vacuum, $\varepsilon = \varepsilon_0$. Furthermore, displacement current exists because of the $\partial \mathbf{D} / \partial t$ term in the generalized Ampere's law added by Maxwell, namely,

$$\nabla \times \mathbf{H} = \frac{\partial \mathbf{D}}{\partial t} + \mathbf{J} \quad (38.2.1)$$

Together with Faraday's law that

$$\nabla \times \mathbf{E} = -\frac{\partial \mathbf{B}}{\partial t} \quad (38.2.2)$$

(38.2.1) and (38.2.2) together allow for the existence of wave. The coupling between the two equations gives rise to the "springiness" of electromagnetic fields.

Wave exists due to the existence of coupled harmonic oscillators, and at a fundamental level, these harmonic oscillators are electron-positron (e-p) pairs. The fact that they are coupled allows waves to propagate through space, and even in vacuum.

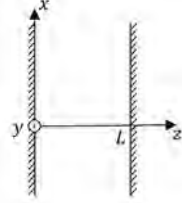


Figure 38.4: A one-dimensional cavity solution to Maxwell's equations is one of the simplest way to solve Maxwell's equations. The oscillation of the electromagnetic fields inside the cavity resembles the oscillation of a simple pendulum.

Simple Cavity Mode

To make the problem simpler, we look at a one dimensional cavity formed by two PEC (perfect electric conductor) plates as shown in Figure 38.4. We assume source-free Maxwell's equations in between the plates and letting $\mathbf{E} = \hat{x}E_x$, $\mathbf{H} = \hat{y}H_y$. Then (38.2.1) and (38.2.2) become

$$\frac{\partial}{\partial z} H_y = -\varepsilon \frac{\partial}{\partial t} E_x \quad (38.2.3)$$

$$\frac{\partial}{\partial z} E_x = -\mu \frac{\partial}{\partial t} H_y \quad (38.2.4)$$

The above are similar to the telegrapher's equations. We can combine them to arrive at

$$\frac{\partial^2}{\partial z^2} E_x = \mu\varepsilon \frac{\partial^2}{\partial t^2} E_x \quad (38.2.5)$$

There are infinitely many ways to solve the above partial differential equation. But here, we use separation of variables to solve the above by letting

$$E_x(z, t) = E_0(t)f(z) \quad (38.2.6)$$

Then we arrive at two separate equations that

$$\frac{d^2 E_0(t)}{dt^2} = -\omega_l^2 E_0(t) \quad (38.2.7)$$

and

$$\frac{d^2 f(z)}{dz^2} = -\omega_l^2 \mu\varepsilon f(z) \quad (38.2.8)$$

where ω_l^2 is the separation constant. There are infinitely many ways to solve the above equations. They are also eigenvalue equations with eigenvalues ω_l^2 and $\omega_l^2 \mu\varepsilon$. The general solutions for (38.2.7) and (38.2.8) are that

$$E_0(t) = E_0 \cos(\omega_l t + \psi) \quad (38.2.9)$$

$$f(z) = \sin(k_l z) \quad (38.2.10)$$

$$k_l = \frac{l\pi}{L}, \quad l = 1, 2, 3, \dots, \quad \omega_l = \frac{l\pi}{L}c, \quad l = 1, 2, 3, \dots \quad (38.2.11)$$

These are the discrete resonant frequencies ω_l of the modes of the 1D cavity.

The above solutions for $E_x(z, t)$ in (38.2.5) can be thought of as the collective oscillations of coupled harmonic oscillators forming the modes of the cavity. At the fundamental level, these oscillations are oscillators made by electron-positron pairs. But macroscopically, their collective resonances manifest themselves as giving rise to infinitely many electromagnetic cavity modes. The amplitudes of these modes, $E_0(t)$ are simple harmonic oscillations.

The resonance between two parallel PEC plates is similar to the resonance of a transmission line of length L shorted at both ends. One can see that the resonance of a shorted transmission line is similar to the coupling of infinitely many LC tank circuits. To see this, as shown in Figure 38.3, we start with a single LC tank circuit as a simple harmonic oscillator with only one resonant frequency. When two LC tank circuits are coupled to each other, they will have two resonant frequencies. For N of them, they will have N resonant frequencies. For a continuum of them, they will be infinitely many resonant frequencies or modes as indicated by Equation (38.2.11).

What is more important is that the resonance of each of these modes is similar to the resonance of a simple pendulum or a simple harmonic oscillator. For a fixed point in space, the field due to this oscillation is similar to the oscillation of a simple pendulum.

Simple Pendulum

As we have seen in the Drude-Lorentz-Sommerfeld mode, for a particle of mass m attached to a spring connected to a wall, where the restoring force is like Hooke's law, the equation of motion of a pendulum by Newton's law is

$$m \frac{d^2 x}{dt^2} + \kappa x = 0 \quad (38.2.12)$$

where κ is the spring constant, and we assume that the oscillator is not driven by an external force, but is in natural or free oscillation. The above equation is homorphic/analogous to (38.2.7). We can see that $x \leftrightarrow E_0$ relates the two equations. By letting²

$$x = x_0 e^{-i\omega t} \quad (38.2.13)$$

the above becomes

$$-m\omega^2 x_0 + \kappa x_0 = 0 \quad (38.2.14)$$

Again, a non-trivial solution is possible only at the resonant frequency of the oscillator or that when $\omega = \omega_0$ where

$$\omega_0 = \sqrt{\frac{\kappa}{m}} \quad (38.2.15)$$

This is the eigensolution of (38.2.12) with eigenvalue ω_0^2 .

38.3 Hamiltonian Mechanics

Equation (38.2.12) can be derived by Newton's law but it can also be derived via Hamiltonian mechanics as well. Since Hamiltonian mechanics motivates quantum mechanics, we will look at the Hamiltonian mechanics view of the equation of motion (EOM) of a simple pendulum given by (38.2.12).

Hamiltonian mechanics, developed by Hamilton (1805-1865) [281], is motivated by energy conservation [282]. The Hamiltonian H of a system is given by its total energy, namely that

$$H = T + V \quad (38.3.1)$$

where T is the kinetic energy and V is the potential energy of the system.

For a simple pendulum, the kinetic energy is given by

$$T = \frac{1}{2} m v^2 = \frac{1}{2m} m^2 v^2 = \frac{p^2}{2m} \quad (38.3.2)$$

²For this part of the lecture, we will switch to using $\exp(-i\omega t)$ time convention as is commonly used in optics and physics literatures.

where $p = mv$ is the momentum of the particle. The potential energy, assuming that the particle is attached to a spring with spring constant κ , is given by

$$V = \frac{1}{2}\kappa x^2 = \frac{1}{2}m\omega_0^2 x^2 \quad (38.3.3)$$

Hence, the Hamiltonian is given by

$$H = T + V = \frac{p^2}{2m} + \frac{1}{2}m\omega_0^2 x^2 \quad (38.3.4)$$

At any instant of time t , we assume that $p(t) = mv(t) = m\frac{d}{dt}x(t)$ is independent of $x(t)$.³ In other words, they can vary independently of each other. But $p(t)$ and $x(t)$ have to time evolve to conserve energy or to keep H , the total energy, constant or independent of time. In other words,

$$\frac{d}{dt}H(p(t), x(t)) = 0 = \frac{dp}{dt} \frac{\partial H}{\partial p} + \frac{dx}{dt} \frac{\partial H}{\partial x} \quad (38.3.5)$$

Therefore, the Hamilton equations of motion are derived to be⁴

$$\frac{dp}{dt} = -\frac{\partial H}{\partial x}, \quad \frac{dx}{dt} = \frac{\partial H}{\partial p} \quad (38.3.6)$$

From (38.3.4), we gather that

$$\frac{\partial H}{\partial x} = m\omega_0^2 x, \quad \frac{\partial H}{\partial p} = \frac{p}{m} \quad (38.3.7)$$

Applying (38.3.6), we have⁵

$$\frac{dp}{dt} = -m\omega_0^2 x, \quad \frac{dx}{dt} = \frac{p}{m} \quad (38.3.8)$$

Combining the two equations in (38.3.8) above, we have

$$m \frac{d^2 x}{dt^2} = -m\omega_0^2 x = -\kappa x \quad (38.3.9)$$

which is also derivable by Newton's law.

A typical harmonic oscillator solution to (38.3.9) is

$$x(t) = x_0 \cos(\omega_0 t + \psi) \quad (38.3.10)$$

The corresponding $p(t) = m\frac{dx}{dt}$ is

$$p(t) = -mx_0\omega_0 \sin(\omega_0 t + \psi) \quad (38.3.11)$$

³ $p(t)$ and $x(t)$ are termed conjugate variables in many textbooks.

⁴Note that the Hamilton equations are determined to within a multiplicative constant, because one has not stipulated the connection between space and time, or we have not calibrated our clock [282].

⁵We can also calibrate our clock here so that it agrees with our definition of momentum in the ensuing equation.

Hence

$$\begin{aligned} H &= \frac{1}{2}m\omega_0^2x_0^2\sin^2(\omega_0t + \psi) + \frac{1}{2}m\omega_0^2x_0^2\cos^2(\omega_0t + \psi) \\ &= \frac{1}{2}m\omega_0^2x_0^2 = E \end{aligned} \quad (38.3.12)$$

And the total energy E is a constant of motion (physicists parlance for a time-independent variable), it depends only on the amplitude x_0 of the oscillation in (38.3.10).

38.4 Schrödinger Equation (1925)

Having seen the Hamiltonian mechanics for describing a simple pendulum which is homomorphic to a cavity resonator, we shall next see the quantum mechanics description of the same simple pendulum: In other words, we will look at the quantum pendulum. To this end, we will invoke Schrödinger equation.

Schrödinger equation cannot be derived just as in the case Maxwell's equations. It is a wonderful result of a postulate and a guessing game based on experimental observations [73, 74]. Hamiltonian mechanics says that

$$H = \frac{p^2}{2m} + \frac{1}{2}m\omega_0^2x^2 = E \quad (38.4.1)$$

where E is the total energy of the oscillator, or pendulum. In classical mechanics, the position x of the particle associated with the pendulum is known with great certainty. But in the quantum world, this position x of the quantum particle is uncertain and is fuzzy. As shall be seen later, x is a random variable.⁶

To build this uncertainty into a quantum harmonic oscillator, one has to look at it from the quantum world. The position of the particle is described by a wave function,⁷ which makes the location of the particle uncertain. To this end, Schrödinger proposed his equation which is a partial differential equation. He was very much motivated by the experimental revelation then that $p = \hbar k$ from De Broglie and that $E = \hbar\omega$ from Planck's law and the photo-electric effect. Equation (38.4.1) can be written more suggestively as

$$\frac{\hbar^2k^2}{2m} + \frac{1}{2}m\omega_0^2x^2 = \hbar\omega \quad (38.4.2)$$

To add more texture to the above equation, one lets the above become an operator equation that operates on a wave function $\psi(x, t)$ so that

$$-\frac{\hbar^2}{2m}\frac{\partial^2}{\partial x^2}\psi(x, t) + \frac{1}{2}m\omega_0^2x^2\psi(x, t) = i\hbar\frac{\partial}{\partial t}\psi(x, t) \quad (38.4.3)$$

⁶For lack of a better notation, we will use x to both denote a position in classical mechanics as well as a random variable in quantum theory.

⁷Since a function is equivalent to a vector, and this wave function describes the state of the quantum system, this is also called a state vector.

If the wave function is of the form

$$\psi(x, t) \sim e^{ikx - i\omega t} \quad (38.4.4)$$

then upon substituting (38.4.4) back into (38.4.3), we retrieve (38.4.2).

Equation (38.4.3) is Schrödinger equation (or the Schrödinger wave equation) in one dimension for the quantum version of the simple harmonic oscillator. In Schrödinger equation, we can further posit that the wave function has the general form

$$\psi(x, t) = e^{ikx - i\omega t} A(x, t) \quad (38.4.5)$$

where $A(x, t)$ is a slowly varying function of x and t , compared to $e^{ikx - i\omega t}$.⁸ In other words, this is the expression for a wave packet. With this wave packet, the $\partial^2/\partial x^2$ can be again approximated by $-k^2$ in the short-wavelength limit, as has been done in the paraxial wave approximation. Furthermore, if the signal is assumed to be quasi-monochromatic, then $i\hbar\partial/\partial t\psi(x, t) \approx \hbar\omega\psi(x, t)$, we again retrieve the classical equation in (38.4.2) from (38.4.3). Hence, the classical equation (38.4.2) is a short wavelength, monochromatic approximation of Schrödinger equation. (However, as we shall see, the solutions to Schrödinger equation are not limited to just wave packets described by (38.4.5).)

Correspondence Principle

In the limit when $\hbar \rightarrow 0$, the quantization energy will be very small, and we expect to retrieve the classical picture or classical mechanics. In fact, when $\hbar \rightarrow 0$, if the particle is to have a finite amount of energy E , the frequency $\omega \rightarrow \infty$. Also, for a particle carrying a finite momentum, $k \rightarrow \infty$ as well. Hence, the wave function $\psi(x, t)$ becomes a very high-frequency wave function or a wave packet. One can see that this wave packet follows the classical equations of motion. This is known as the correspondence principle.

Wave functions

In classical mechanics, the position of a particle is described by the variable x , but in the quantum world, the position of a particle x is a random variable. This property needs to be related to the wave function that is the solution to Schrödinger equation.

For this course, we need only to study the one-dimensional Schrödinger equation. The above can be converted into eigenvalue problem, just as in waveguide and cavity problems, using separation of variables, by letting⁹

$$\psi(x, t) = \psi_n(x)e^{-i\omega_n t} \quad (38.4.6)$$

By so doing, (38.4.3) becomes an eigenvalue problem

$$\left[-\frac{\hbar^2}{2m} \frac{d^2}{dx^2} + \frac{1}{2}m\omega_0^2 x^2 \right] \psi_n(x) = E_n \psi_n(x) \quad (38.4.7)$$

⁸Recall that this is similar in spirit when we study high frequency solutions of Maxwell's equations and paraxial wave approximation.

⁹Mind you, the following is ω_n , not ω_0 .

where $E_n = \hbar\omega_n$ is the eigenvalue while $\psi_n(x)$ is the corresponding eigenfunction.

The parabolic x^2 potential profile is also known as a potential well as it can provide the restoring force to keep the particle bound to the well classically (see Section 38.3 and (38.3.8)). (The above equation is also similar to the electromagnetic equation for a dielectric slab waveguide, where the second term is a dielectric profile (mind you, varying in the x direction) that can trap a waveguide mode. Therefore, the potential well is a trap for the particle both in classical mechanics or in wave physics.)

The above equation (38.4.7) can be solved in closed form in terms of Hermite-Gaussian functions (1864) [283], or that

$$\psi_n(x) = \sqrt{\frac{1}{2^n n!} \sqrt{\frac{m\omega_0}{\pi\hbar}}} e^{-\frac{m\omega_0}{2\hbar} x^2} H_n \left(\sqrt{\frac{m\omega_0}{\hbar}} x \right) \quad (38.4.8)$$

where $H_n(y)$ is a Hermite polynomial, and the eigenvalues are found in closed form as

$$E_n = \left(n + \frac{1}{2} \right) \hbar\omega_0 \quad (38.4.9)$$

Here, the eigenfunction or eigenstate $\psi_n(x)$ is known as the photon number state (or just a number state) of the solution. It corresponds to having n “photons” in the oscillation. If this is conceived as the collective oscillation of the e-p pairs in a cavity, there are n photons corresponding to energy of $n\hbar\omega_0$ embedded in the collective oscillation. The larger E_n is, the larger the number of photons there is. (However, there is a curious mode at $n = 0$. This corresponds to no photon, and yet, there is a wave function $\psi_0(x)$. This is the zero-point energy state. This state is there even if the system is at its lowest energy state.)

It is to be noted that in the quantum world, the position x of the pendulum is random. Moreover, this position $x(t)$ is mapped to the amplitude $E_0(t)$ of the field. Hence, it is the amplitude of an electromagnetic oscillation that becomes uncertain and fuzzy as shown in Figure 38.5.

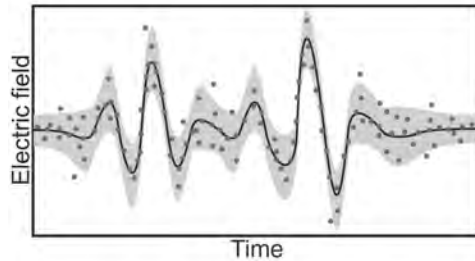


Figure 38.5: Schematic representation of the randomness of the measured electric field. The electric field amplitude maps to the displacement (position) of the quantum harmonic oscillator, which is a random variable (courtesy of Kira and Koch [284]).

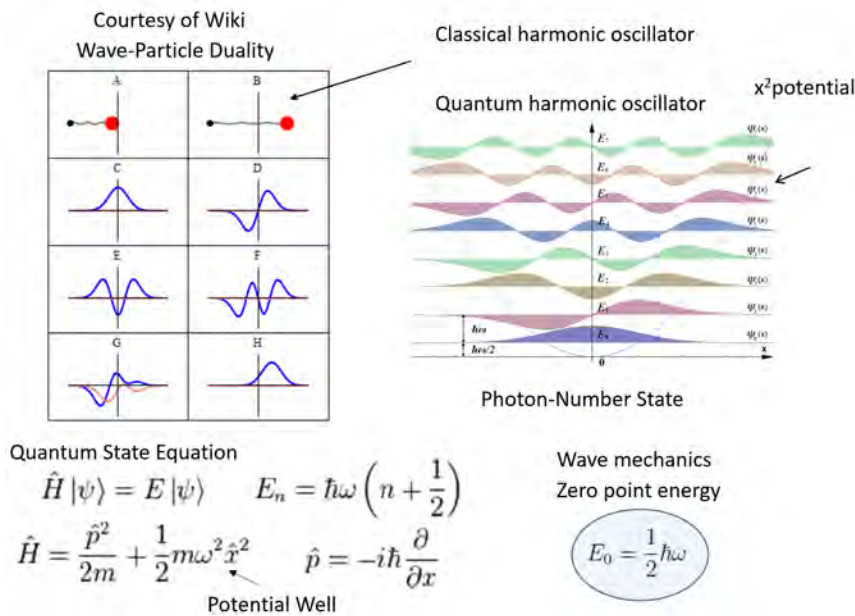


Figure 38.6: Plots of the eigensolutions of the quantum harmonic oscillator. The photon-number states are non-classical states because they do not have a classical analogue (courtesy of Wikipedia [285]).

38.5 Some Quantum Interpretations—A Preview

Schrödinger used his equation with resounding success. He derived a three-dimensional version of this to study the wave function and eigenvalues of a hydrogen atom. These eigenvalues E_n for a hydrogen atom agreed well with experimental observations that had eluded scientists for decades. Schrödinger did not actually understand what these wave functions meant. It was Max Born (1926) who gave a physical interpretation of these wave functions.

As mentioned before, in the quantum world, a position x is now a random variable. There is a probability distribution function (PDF) associated with this random variable x . This PDF for x is related to the a wave function $\psi(x, t)$, and it is given $|\psi(x, t)|^2$. Then according to probability theory, the probability of finding the particles in the interval¹⁰ $[x, x + \Delta x]$ is $|\psi(x, t)|^2 \Delta x$. Since $|\psi(x, t)|^2$ is a probability density function (PDF), and it is necessary that

$$\int_{-\infty}^{\infty} dx |\psi(x, t)|^2 = 1 \tag{38.5.1}$$

¹⁰This is the math notation for an interval $[,]$.

The average value or expectation value of the random variable x is now given by

$$\int_{-\infty}^{\infty} dx x |\psi(x, t)|^2 = \langle x(t) \rangle = \bar{x}(t) \quad (38.5.2)$$

This is not the most ideal notation, since although x is not a function of time, its expectation value with respect to a time-varying function, $\psi(x, t)$, can be time-varying.

Notice that in going from (38.4.1) to (38.4.3), or from a classical picture to a quantum picture, we have let the momentum become p , originally a scalar number in the classical world, become a differential operator, namely that¹¹

$$p \rightarrow \hat{p} = -i\hbar \frac{\partial}{\partial x} \quad (38.5.3)$$

The momentum p of a particle now also becomes uncertain and is a random variable: its expectation value is given by¹²

$$\int_{-\infty}^{\infty} dx \psi^*(x, t) \hat{p} \psi(x, t) = -i\hbar \int_{-\infty}^{\infty} dx \psi^*(x, t) \frac{\partial}{\partial x} \psi(x, t) = \langle \hat{p}(t) \rangle = \bar{p}(t) \quad (38.5.4)$$

The expectation values of position x and the momentum operator \hat{p} are measurable in the laboratory. Hence, they are also called observables.

38.5.1 Matrix or Operator Representations

We have seen in computational electromagnetics that an operator can be projected into a smaller subspace and manifests itself in different representations. Hence, an operator in quantum theory can have different representations depending on the space chosen. For instance, given a matrix equation

$$\bar{\mathbf{P}} \cdot \mathbf{x} = \mathbf{b} \quad (38.5.5)$$

we can find a unitary operator $\bar{\mathbf{U}}$ with the property $\bar{\mathbf{U}}^\dagger \cdot \bar{\mathbf{U}} = \bar{\mathbf{I}}$. Then the above equation can now be rewritten as

$$\bar{\mathbf{U}} \cdot \bar{\mathbf{P}} \cdot \mathbf{x} = \bar{\mathbf{U}} \cdot \mathbf{b} \rightarrow \bar{\mathbf{U}} \cdot \bar{\mathbf{P}} \cdot \bar{\mathbf{U}}^\dagger \cdot \bar{\mathbf{U}} \cdot \mathbf{x} = \bar{\mathbf{U}} \cdot \mathbf{b} \quad (38.5.6)$$

Then a new equation is obtained such that

$$\bar{\mathbf{P}}' \cdot \mathbf{x}' = \mathbf{b}', \quad \bar{\mathbf{P}}' = \bar{\mathbf{U}} \cdot \bar{\mathbf{P}} \cdot \bar{\mathbf{U}}^\dagger, \quad \mathbf{x}' = \bar{\mathbf{U}} \cdot \mathbf{x} \quad \mathbf{b}' = \bar{\mathbf{U}} \cdot \mathbf{b} \quad (38.5.7)$$

The above can be extended to infinite dimensional linear vector spaces or Hilbert spaces.

The operators we have encountered thus far in Schrödinger equation are in coordinate space representation.¹³ In coordinate space representation, the momentum operator $\hat{p} =$

¹¹We use $\hat{}$ to denote a quantum operator.

¹²This concept of the average of an operator seldom has an analogue in an intro probability course, but it is called the expectation value of an operator in quantum theory.

¹³Or just coordinate representation.

$-i\hbar\frac{\partial}{\partial x}$, and the variable x can be regarded as a position operator in coordinate space representation. The operator \hat{p} and x do not commute. In other words, it can be shown that

$$[\hat{p}, x] = \left[-i\hbar\frac{\partial}{\partial x}, x \right] = -i\hbar \quad (38.5.8)$$

In the classical world, $[p, x] = 0$, but not in the quantum world. In the equation above, we can elevate x to become an operator by letting $\hat{x} = x\hat{I}$, where \hat{I} is the identity operator. Then both \hat{p} and \hat{x} are now operators, and are on the same footing. In this manner, we can rewrite equation (38.5.8) above as

$$[\hat{p}, \hat{x}] = -i\hbar\hat{I} \quad (38.5.9)$$

By performing unitary transformation, it can be shown that the above identity is space independent: it is true in any representation of the operators.

It can be shown easily that when two operators share the same set of eigenfunctions, they commute. When two operators \hat{p} and \hat{x} do not commute, it means that the expectation values of quantities associated with the operators, $\langle\hat{p}\rangle$ and $\langle\hat{x}\rangle$, cannot be determined to arbitrary precision simultaneously. For instance, \hat{p} and \hat{x} correspond to random variables, then the standard deviation of their measurable values, or their expectation values, obey the uncertainty principle relationship that¹⁴

$$\Delta p \Delta x \geq \hbar/2 \quad (38.5.10)$$

where Δp and Δx are the standard deviation of the random variables p and x .

38.6 Bizarre Nature of the Photon Number States

The photon number states are successful in predicting that the collective e-p oscillations are associated with n photons embedded in the energy of the oscillating modes. However, these number states are bizarre: The expectation values of the position of the quantum pendulum associated these states are always zero. To illustrate further, we form the wave function with a photon-number state

$$\psi(x, t) = \psi_n(x)e^{-i\omega_n t}$$

Previously, since the $\psi_n(x)$ are eigenfunctions, they are mutually orthogonal and they can be orthonormalized meaning that

$$\int_{-\infty}^{\infty} dx \psi_n^*(x) \psi_{n'}(x) = \delta_{nn'} \quad (38.6.1)$$

Then one can easily show that the expectation value of the position of the quantum pendulum in a photon number state is

$$\langle x(t) \rangle = \bar{x}(t) = \int_{-\infty}^{\infty} dx x |\psi(x, t)|^2 = \int_{-\infty}^{\infty} dx x |\psi_n(x)|^2 = 0 \quad (38.6.2)$$

¹⁴The proof of this is quite straightforward but is outside the scope of this course.

because the integrand is always odd symmetric. In other words, the expectation value of the position x of the pendulum is always zero. It can also be shown that the expectation value of the momentum operator \hat{p} is also zero for these photon number states. Hence, there are no classical oscillations that resemble them. Therefore, one has to form new wave functions by linear superposing these photon number states into a coherent state. This will be the discussion in the next lecture.

